

BUILDING CALCULATIONS PRACTICE EXERCISES

CERTIFICATE IN BUILDING LEVEL 4



THE SCHOOL OF TRADES, ENGINEERING AND CONSTRUCTION

create your world
www.wintec.ac.nz



Wintec
WAIKATO INSTITUTE OF TECHNOLOGY
Te Kuratini o Waikato

Contents

Element 1: Linear measurement systems	3
Element 2: Right-angled triangle trigonometry	8
Element 3: Perimeters	16
Area	20
Volume	24
Percentages	28

Note:

- You are required to show all workings for all questions.
- Each answer given should show the correct decimal placing.
- Each answer given should express the correct metric unit, i.e. mm, m², m³.

Element 1: Linear Measurement Systems

Use floor plan A (p. 5) to answer the following questions.

1. What are the internal dimensions of the kitchen (i.e. length and width)?

2. What are the external dimensions of the shower?

3. What is the internal dimension for the following?

- a. Bathroom basin (vanity)

- b. Laundry tub and washing machine

4. What is the length of the living room, including the cupboard space?

5. What are the internal dimensions (length and width) of the hallway to bedrooms 1 and 2?

6. How many framing studs are required for wall frame B, with the studs spaced at 600 mm centres? **(Remember to use the 'one for nothing' rule.)**

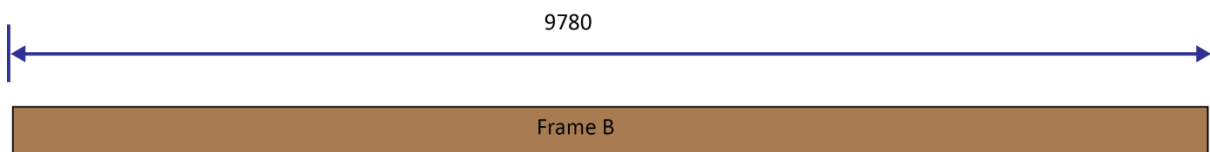

7. When working out the correct amount of framing members (i.e. studs) for a wall: **(Circle the correct answer.)**
- a. Add one extra framing member to the total amount of spaces, to get the correct answer.
 - b. Add one extra space to the total amount of studs, to get the correct answer.
 - c. Divide the overall length by the member spacing, to get the correct answer.
8. What is the in between measurement for 50 mm framing members spaced at 400 mm centres?

9. When setting out framing, what is the most practical linear measurement method to use? (Circle the correct answer.)

- a. Centre to centre
- b. In and over
- c. In between

10. When calculating the length of a nog between framing members, what is the most practical linear measurement method to use? (Circle the correct answer.)

- a. Centre to centre
- b. In and over
- c. In between

11. **Fill in the two missing words.**

Centre to centre dimensions are stated in the working drawings to advise the
s _____ d _____ that the framing members are
required to be.

12. An example of a linear measurement method is shown below. Name the method.



Element 2: Right-angled Triangle Trigonometry

1. Using a calculator and Pythagoras' theorem, calculate the hypotenuse on the following shapes. **(Show all your workings.)**

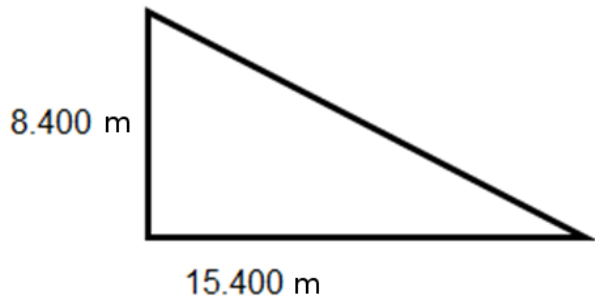

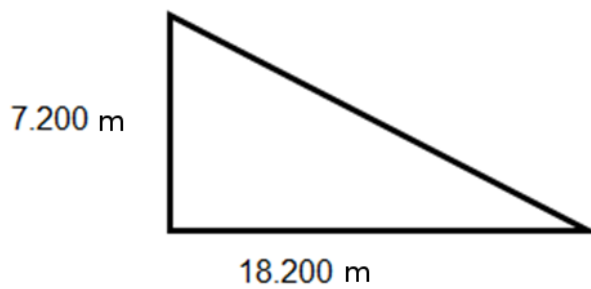

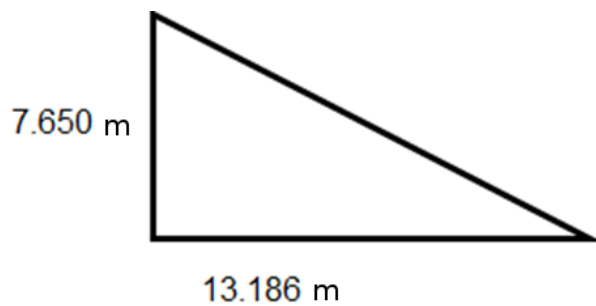

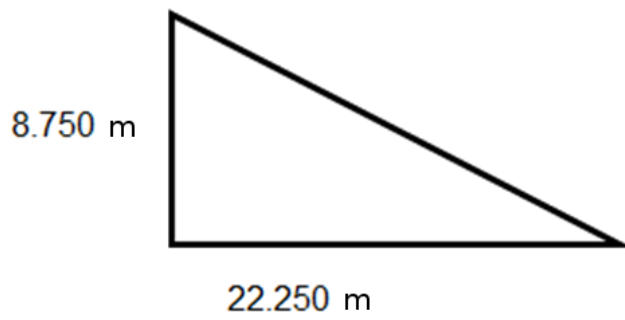

Remember:

In a right-angled triangle, the square on the hypotenuse is equal to the sum of the squares on the two other sides.

2. Using a calculator and Pythagoras Theorem, calculate the length of side x.
(Show all your workings.)

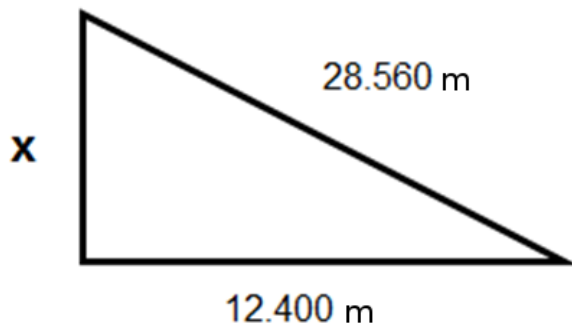

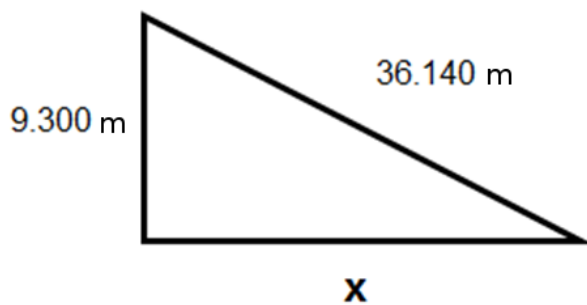

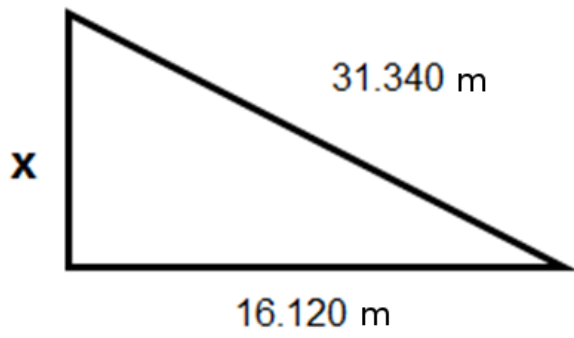

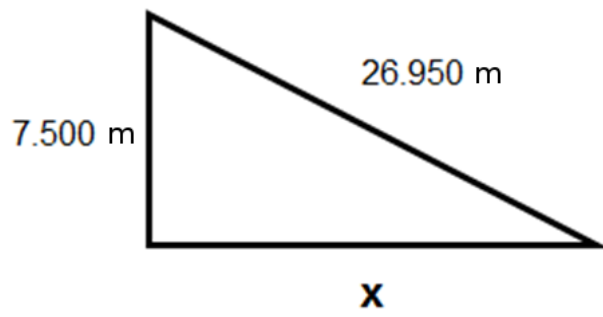

3. Using floor plan **B** (p.12), calculate the diagonal length to the external corners of:
- a. the floor indicated in the square marked **A**
 - b. the rectangle marked **B**

A

B

Floor Plan B

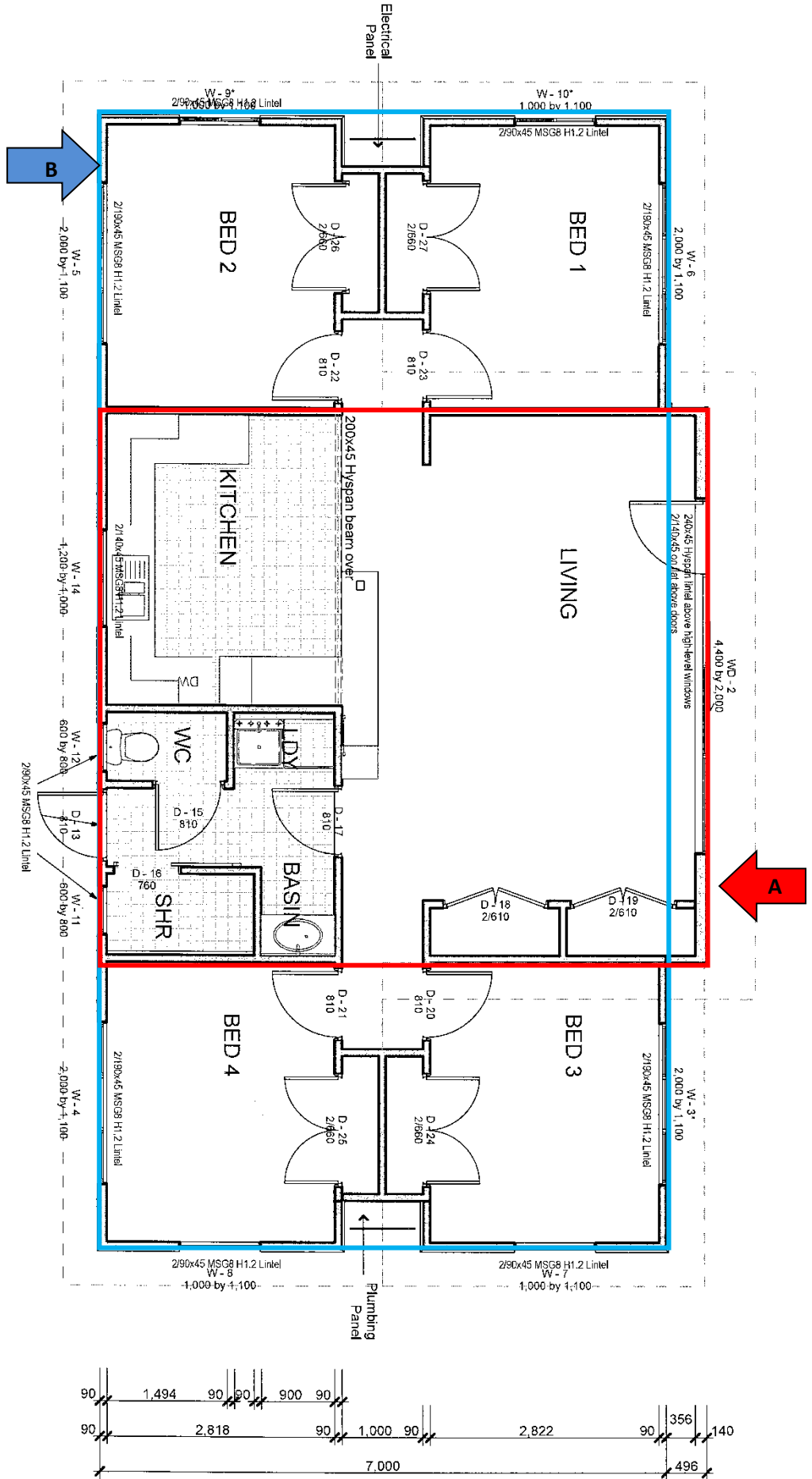
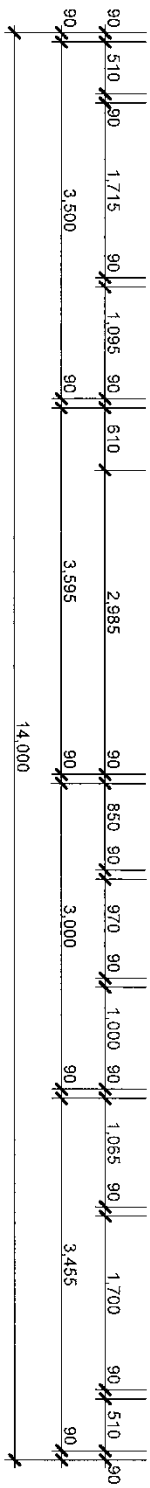

4. A building is to be set out using string lines. The dimensions are 10 m long by 5 m wide. Calculate the diagonal length of the building.

5. A flight of stairs to be constructed has a diagonal length of 7.3 m and a vertical height of 4.0 m. Calculate the horizontal length of the stairs.

6. A metal angle brace has a diagonal length of 3.6 m and a vertical height of 2.4 m. Calculate the horizontal length.

7. Calculate the missing angles. (Show all your workings.)

Remember:

The sum of the three internal angles of a triangle is 180° (i.e. the internal angles of a triangle will always add up to 180°).

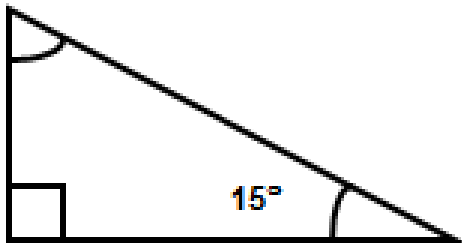

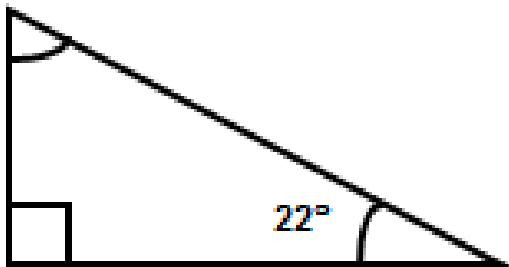

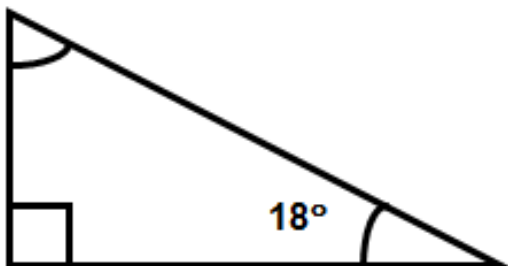

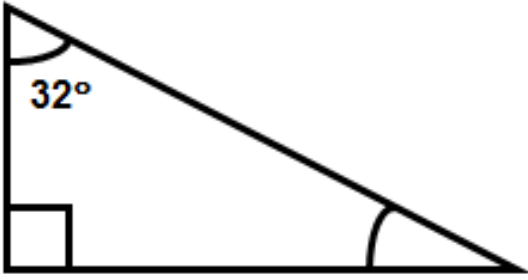

Element 3: Perimeter, Area, Volume, Percentages

I. Perimeter (Circumference)

1. Using floor plan C (p18), calculate the internal perimeter of the outside wall marked A. Remember to take away the width of wall frames. (**Show all your workings.**)

2. Calculate the amount of skirting required for bedroom three, excluding the interior of the wardrobe.

3. Using Pythagoras' theorem, calculate the length of the rafter marked **B** from cross section **A** and floor plan **C** (p.18). The rafter is 90 mm wide. **(Show all your workings.)**

Cross Section A

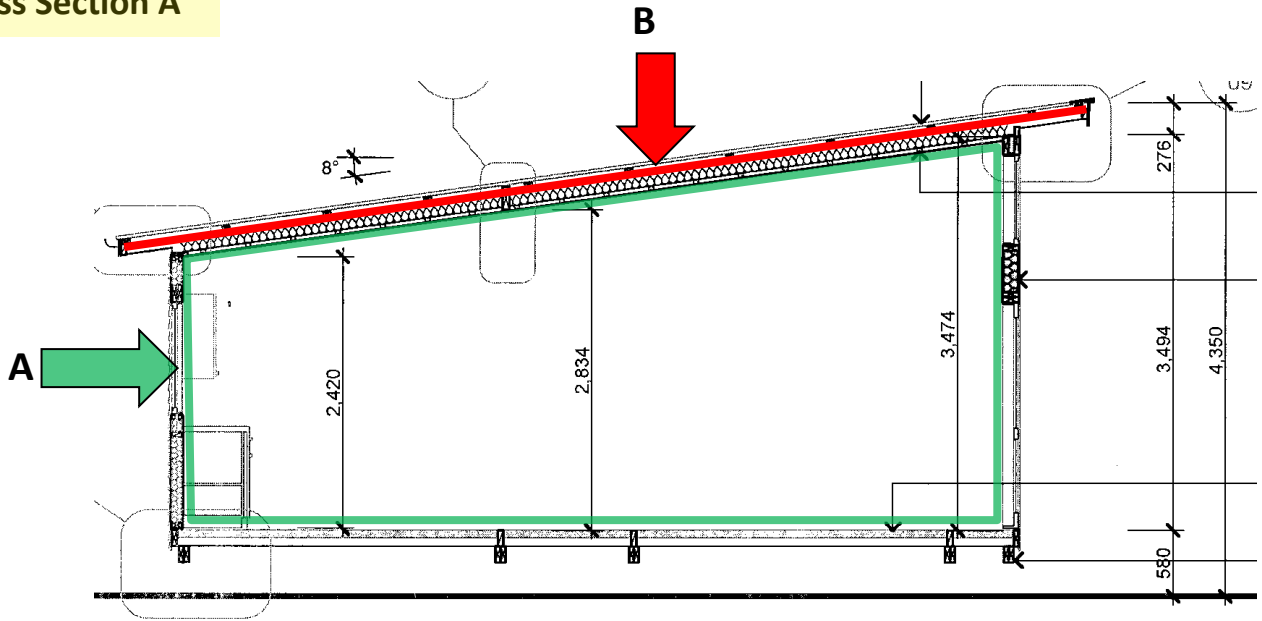

Floor Plan C

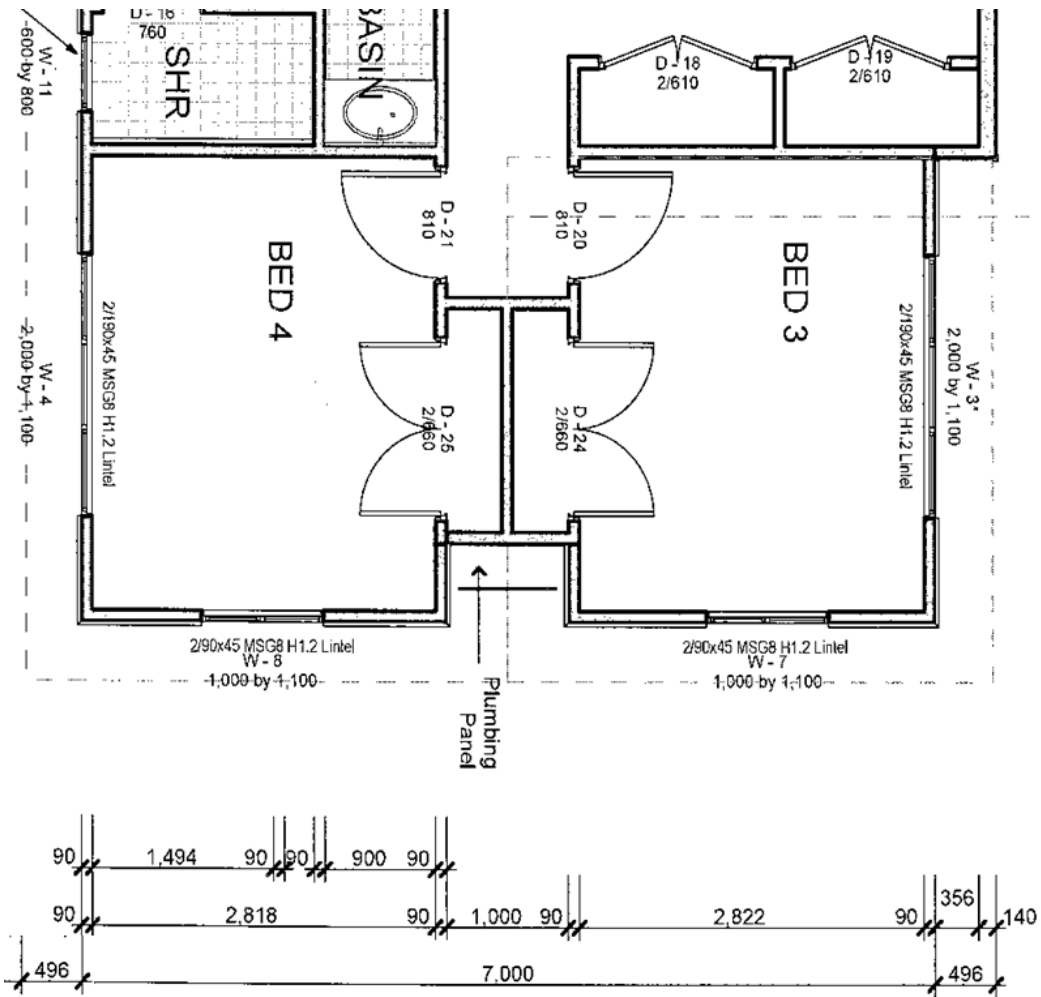

Finding the Circumference or Perimeter of a Circle

4. Pi has a numerical value of _____

(Fill in the missing number.)

5. To calculate the circumference of a circle, multiply the _____
by the numerical value of Pi.

(Fill in the missing word.)

6. Find the circumference (or perimeter) of the following circles.

(Show all your workings.)

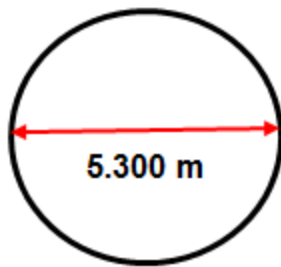

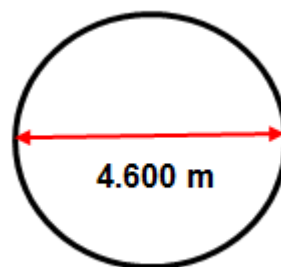

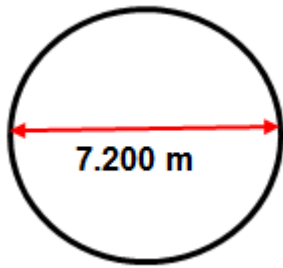

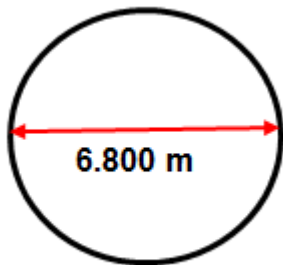

II. Area

7. Area is the measurement of _____ covered.
(Fill in the missing word.)

8. Find the area of the following shapes.

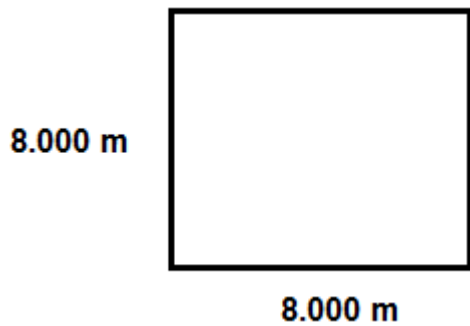

8.000 m



16.000 m

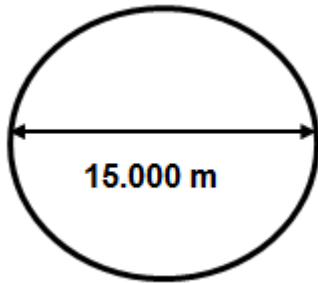

15.000 m

8.000 m

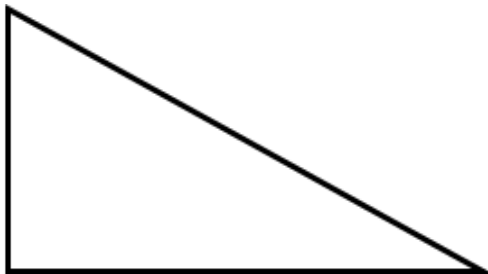

16.000 m

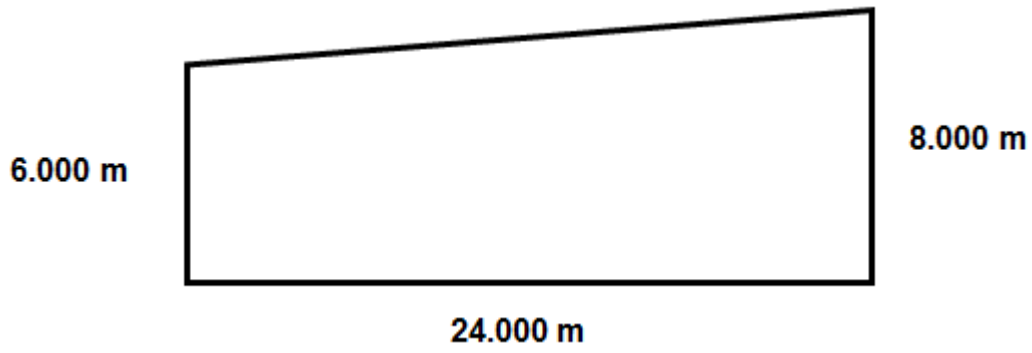

9. Using the working drawings on page 18, find the area of the internal side of the wall from Cross Section A.

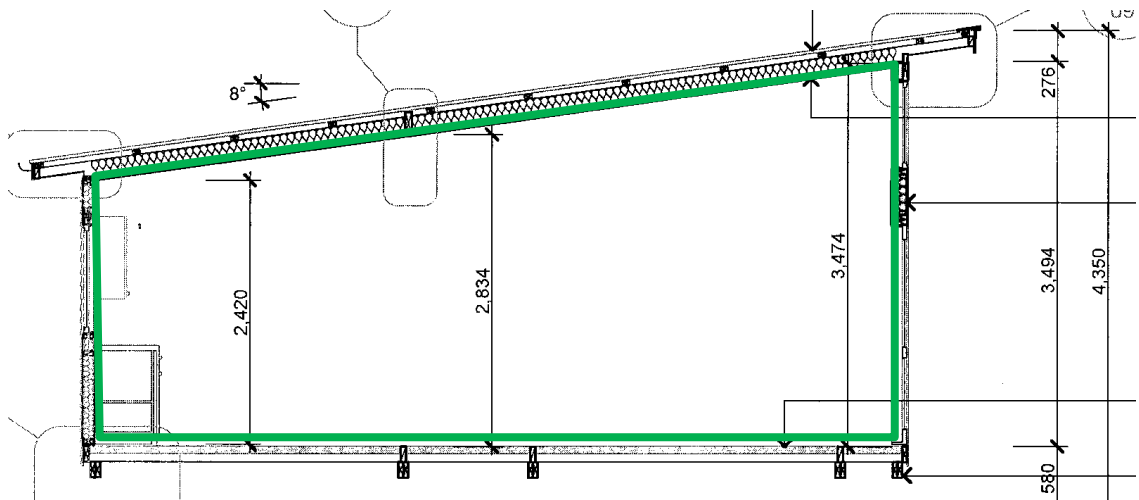

10. Using floor plan **A** on page 5, work out the total area of the floor.

11. Now that you have the total area of the floor, how many flooring sheets, at a size of 2.700 m x 1.200 m, will you need?

III. Volume

12. When calculating volume, three measurements are needed. What are those measurements?

a. _____

b. _____

c. _____

13.

a. Calculate the volume of concrete needed to fill the four square pile holes below. The dimensions of each hole are **L** 400 mm x **W** 400 mm x **D** 450 mm.

First, work out the volume of one hole.

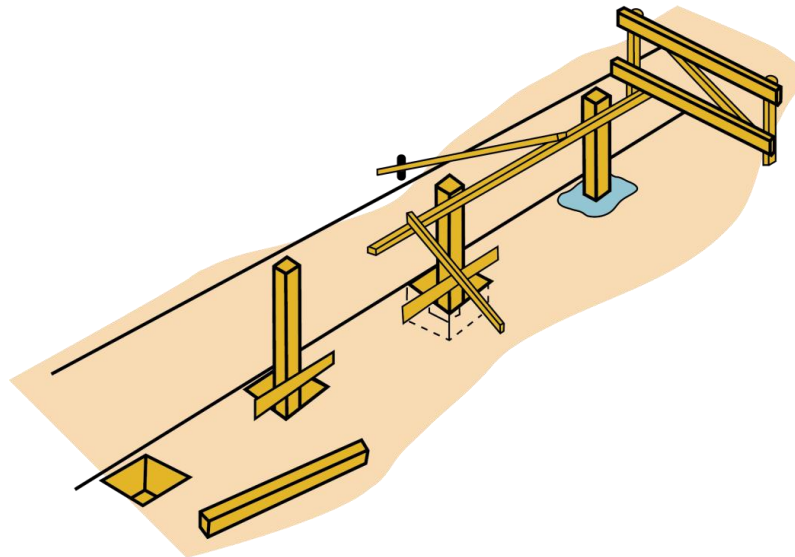

- b. Now that you have calculated the volume of the holes, you will need to subtract the volume of the piles. Remember a pile is required to sit above the bottom of the hole by 100 mm.
The dimensions of the piles are 150 mm x 150 mm.
(The remaining answer will be the amount of concrete required.)

14. Calculate the volume of concrete used for footing A.

Footing Wall A

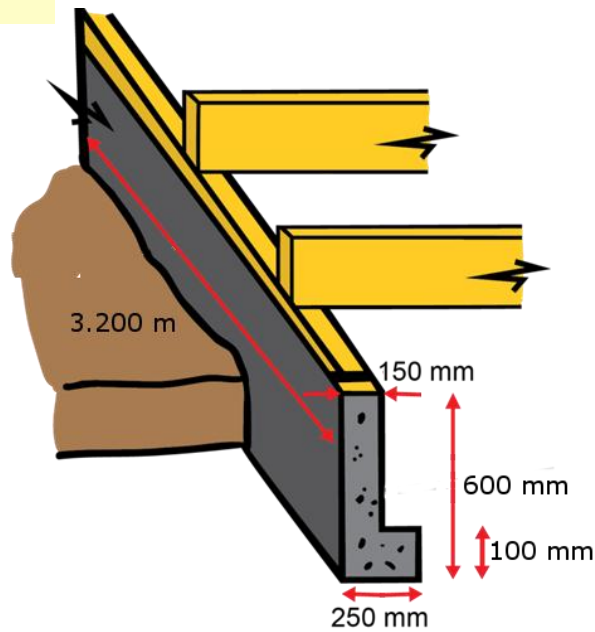

15. Calculate the volume of concrete used for footing B.

Footing Wall B

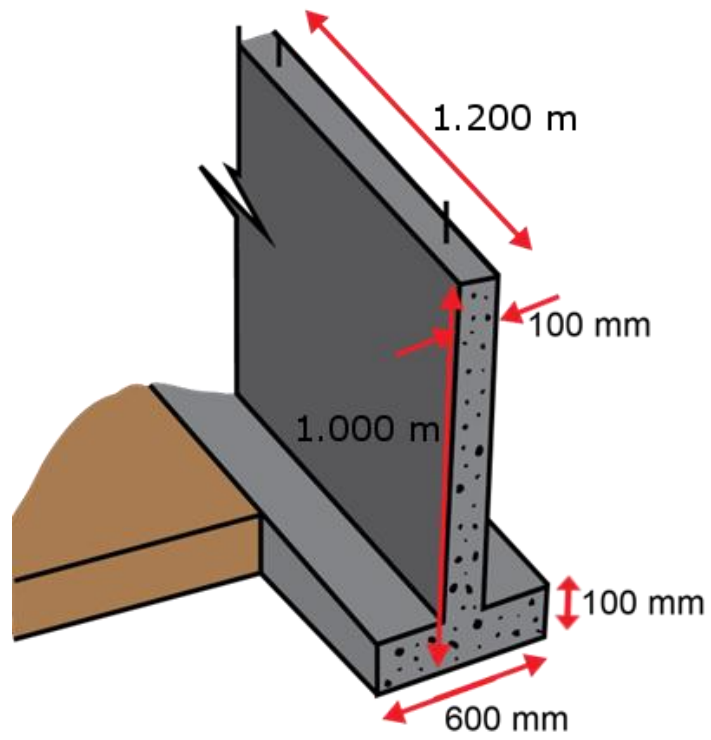

16.
a. Calculate the volume of concrete used for the round concrete pile and its footing C below.

Pile and Footing C

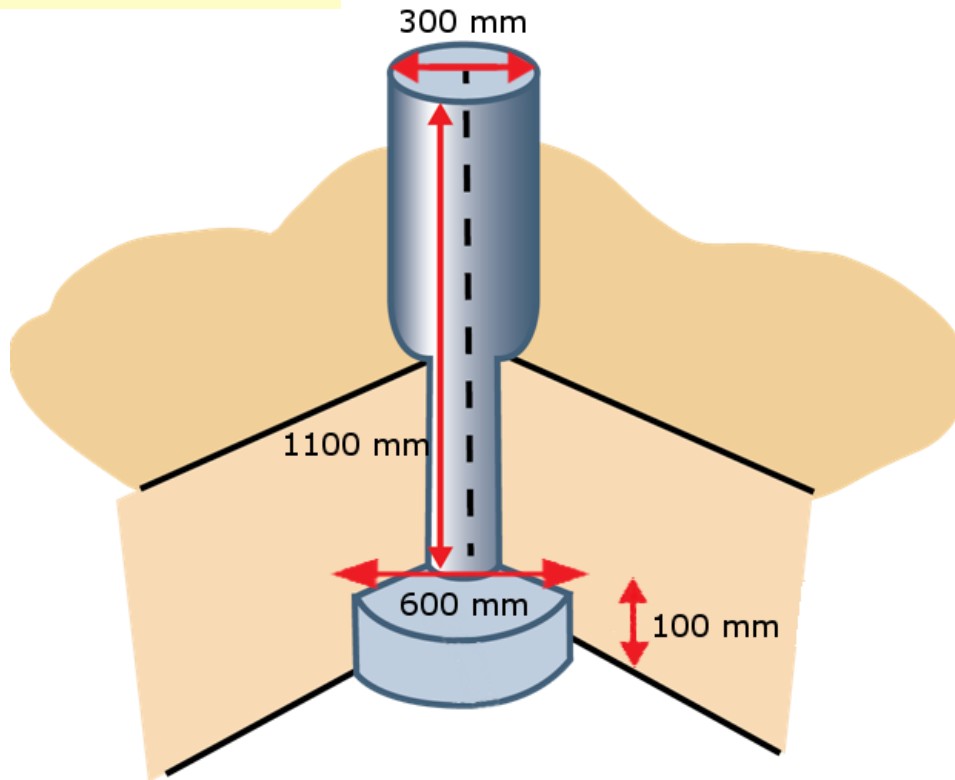

- b. Calculate the amount of concrete required for 26 round piles and footings.

Percentages

17. Express $\frac{35}{100}$ as a percentage.

18. Express $\frac{3}{8}$ as a percentage.

19. Express $\frac{9}{20}$ as a percentage.

20. Write 12.5% as a decimal.

21. Write 15% as a decimal.

22. Write 22% as a decimal.

23. Express 0.28 as a percentage.

24. Express 0.15 as a percentage.

25. Express 0.5 as a percentage.

26. **(Fill in the missing words.)**

The amount by which a quantity can be increased or decreased can be found by

_____ the original _____ by the _____ of increase or decrease, providing the new cost and the old cost are known, by using the formula:

$$\text{percentage} = \frac{\text{amount of increase or decrease}}{\text{original amount}} \times 100$$

27. A new work van was bought for \$25,000. After two years, its value was assessed at \$19,200. What was the percentage decrease in value over the two-year period?

28. Due to a shortage in graded timber, 100 x 50 mm MSG8 timber has increased by 20%. Before the increase, 100 x 50 mm MSG 8 sold for \$6.50 per metre. What price would you now expect to pay per metre for 100 x 50 mm MSG 8?

29. A delivery of timber last year cost \$67.00. This year, the same amount costs \$85.00. What percentage increase does this represent?

30. Add 15% to the following:

a. \$14.25

b. \$1,500

c. \$28.50

31. Discount 8% from the following:

a. \$2,542

b. \$72.40

c. \$ 4.60

End of practice exercises

create your world
www.wintec.ac.nz

